

The **Rock Grotto**

JLH Ripple Eater

Not-for-profit DIY Audio Group Buy to benefit Cancer Research UK

Build Manual v1.0

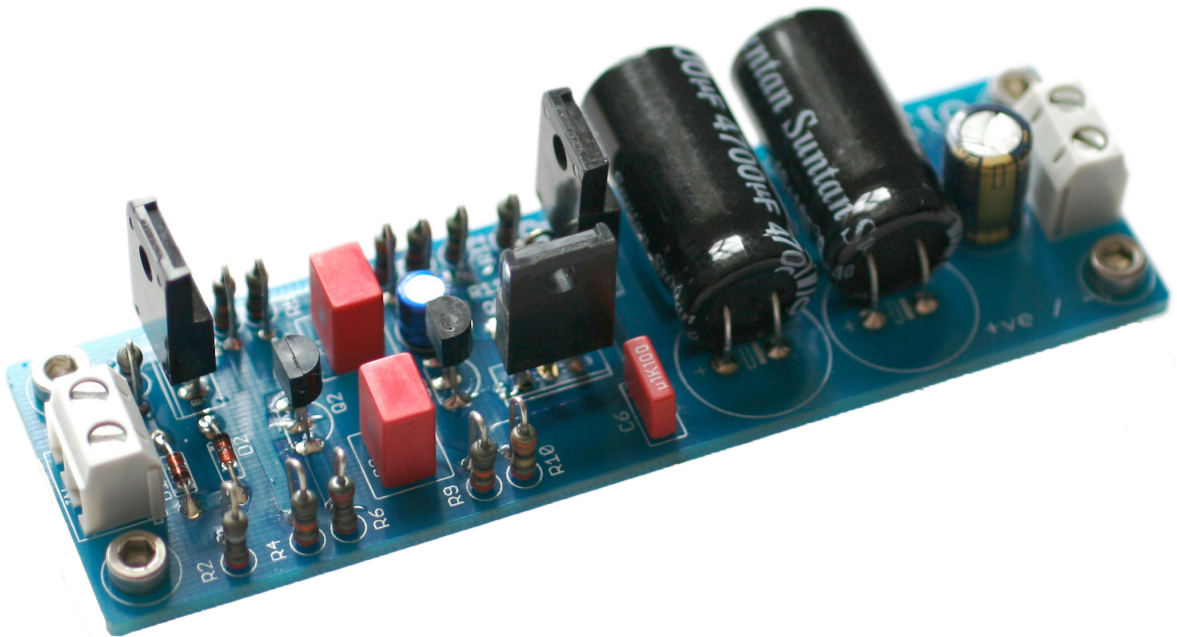

JLH Ripple Eater

Terms and Conditions of Sale / Warning and Disclaimer

This project schematic is used with the agreement of Wimborne Publishing Limited. All trademarks remain the property of their respective owners. This PCB was developed at the **Rock Grotto** audio forum and support is readily available from the nice folk over there! Many thanks to these organizations for their support for this project

To order your boards, please refer to Section IV.

By ordering this board, you agree to the following terms and conditions:

This device was originally designed by the late John Linsley Hood MIEE, and published in April 1994. The design has been modified to increase performance using modern components and design tweaks. The PCB layout is a new, double-sided design. This design has been validated by a test build on hand-etched PCBs, and also additional builds using final version PCBs and published BOM. One of these builds supplied the photos included in this document.

This project does not in itself use line/mains voltages. However, nearly all DIY electronics projects expose the builder to line/mains voltages at one time or another. These voltages can kill – even at miniscule current. If you are not competent / confident with working with these voltages, please seek advice from either a qualified electrician, or an audio DIYer who is competent and experienced in this area. Always work safe and work smart!

The original schematic has been updated and a new PCB layout devised. This PCB is offered **without any warranty, guarantee provided or liability taken by us**. JLH himself stated that he could not guarantee it would improve audio, but that his test instruments proved it did a useful job in cleaning up power supplies. This is a low-voltage, low current design. Users report improvements when used with the SC Headphone Amp and DAC. This is a 500mA or less current, and +-15VDC application. This board is designed using thicker than standard traces, but it has not been proven to work above 650mA. If you try to misuse it, and set fire to yourself, your pet, your house etc, it's your own fault. Likewise, if you like to solder in the nude and drop your iron into your lap, it's your own fault. If you blow up your headphone amp, DAC, hi-fi etc when using this PCB, it is not our fault.

With all that said, this build manual will allow you to complete the build with minimal fuss. This project is suitable for beginners, and all you need do is read this manual carefully and apply, as always, a modicum of common sense. Post any questions on the build thread at **Rock Grotto**.

But, most importantly, have Fun!

Table of Contents

Part I - Introduction

Introduction.....	4
Board Images (EAGLE Capture).....	7

Part II - Bill Of Materials

Positive Version.....	9
Negative Version and Notes.....	10

Part III - Building

Introduction.....	12
Building Preparation.....	12
BOM.....	12
Building Techniques.....	12
The Build.....	14
Testing.....	16
<i>J L H R i p p l e E a t e r</i> In Action.....	18

Part IV Ordering Information

Ordering Information.....	19
---------------------------	----

Part V Built Board Pictures and BOM Mate TM

Built Board Pictures.....	20
BOM Mate TM Positive.....	21
BOM Mate TM Negative.....	22

Part I - Introduction

The **Rock Grotto**

JLH Ripple Eater

Not-for-profit DIY Audio Group Buy to benefit Cancer Research UK

This is a high-quality, professionally produced, double-sided PCB measuring 103mm x 31mm (4.06 x 1.22 ins approx). It may be used to smooth positive or negative power supplies in high-quality audio equipment. The notes below are largely based on JLH's 1994 article.

History behind JLH Ripple Eater – original article.

The original circuit was designed by John Linsley Hood MIEE (February 9, 1925 to March 11, 2004) and published in Electronics Today International in April 1994. Further development of the circuit and layout has taken place over recent years by members of **Rock Grotto** forums - <http://rockgrotto.proboards.com/index.cgi> - where the circuit is used to clean up power supplies on DIY headphone amplifiers and DACs.

What is it?

The JLH Power Supply Ripple Eater is an add-on circuit that sits between a power supply and end user. The Ripple Eater measurably reduces power supply output noise and ripple. JLH demonstrated a reduction in noise and ripple on his own bench supply from a figure, measured over the range of 20Hz to 20KHz, of 300uV to 4uV. When he connected a good quality 470uF electrolytic capacitor across the same bench power supply, there was no measurable improvement in ripple. In a similar experiment, the output noise from a selected 7815 IC voltage regulator was reduced from 60uV, itself better than the maker's specification, to 3.5uV, when measured over the same bandwidth.

Why would you need one?

Need a quieter power supply? Of course you do!! Although JLH was reluctant to claim that this add-on circuit would lead to an improvement in the sound of audio equipment operated from simple IC stabilised power supplies, because he could not know what other people would hear, he was satisfied that, according to his test instruments, it did a useful job.

We think JLH was being modest. Many JLH Ripple Eater users report audible improvements when using this circuit in their power supply chain. Many users report that the improvements brought about by the PSRR are most apparent after 72hrs, once capacitor forming has completed

How does it work?

The circuit consists of two parts: a 'ripple detector' arrangement based on a long-tailed pair, and a constant current source. Any ripple voltage present across the supply line can modulate this current. The aim being that if the output voltage were to momentarily increase or decrease, the current drawn would automatically increase or decrease to oppose these output voltage fluctuations. The impedance of the circuit depends on the size of the capacitors used – particularly that of C4, which can be large since it only needs to be 1V working. With the values chosen in this iteration, the circuit generates the electronic equivalent of about half a Farad or more.

It's also been observed "In essence it is an AC feedback loop".

The original article contained a full circuit and application description, some of which I have paraphrased here. JLH also provided explanatory diagrams, a schematic (with two R8 - a typo that the eagle-eyed amongst you will spot), and a suggested PCB layout. The board may be used for either positive or negative polarity power supplies, given the correct electrolytic capacitor orientation and NPN/PNP transistors. An amended version of the original schematic is at the bottom of this page.

Modifications to original circuit?

The original circuit has been subject to a few modifications in order to improve the already impressive performance of this ingenious circuit. See the schematic diagram at the foot of the page.

Q6 should be replaced by an appropriate Toshiba device when using with higher currents and output voltages, (opposite polarity to the others) as for a brief moment on start up, the power ratings of the original BC639 and BC640 will be greatly exceeded. Thus, many months later, they will eventually fail, with a small bulge showing at the front lettering of the device.

The emitter resistor value of the CL is reduced when a higher current limit is desired, and it will also be necessary to increase the CL's base current by reducing its base resistor's value. e.g. from 4K7 to 1K8. This keeps this transistor acting as a fully saturated switch before the current limiting set by the 2 diodes is reached. Up until that point it is purely a switching device with its emitter resistor governing the devices collector current.

Why the new edition?

We were considering a new iteration of this design. A double-sided version that was slightly more compact than the original. This would also be a single board that could be stacked for a smaller in-chassis footprint.

This non-commercial, non-profit GB will allow a small levy per board to be donated to Cancer Research UK. We have contacted Wimborne Publishing, and hope to submit a revised JLH Ripple Eater article to bring the project up to date some 16 years after original publication. Wimborne

Publishing acquired ETI and brought it into the "Everyday Practical Electronics" (EPE) fold in February 1999.

The board design was finalized with the following features: double-sided layout, through-hole plating, blue solder mask, gold flashed pads, 70um copper traces (2oz / sq ft), 2mm FR4 board material, electrically tested etc.

Who benefits?

For a start, a good cause. At a cost of £3 per board (plus postage and packing) there will be an amount of money raised over costs/forum donations, and 100% of that will be donated to Cancer Research UK. But the real winner will be YOU, as you sit back and enjoy the improved performance of your headphone amp, DAC or whatever.

How do I order my boards?

This is a limited run of 400 boards, and these will be sold on a first-come, first-served basis. To order, please refer to Section IV. Boards cost £3 (three GB Pounds) EACH – you will most likely need pairs for your application. By ordering, you agree that you have read and understood the contents of this manual and are bound by the Ts and Cs. PayPal is the preferred Payment method for UK orders, and is the only method for overseas orders. Postage is at cost, and postal rates published are zoned. Any customs charges fall to you, and only actual board values will be placed on customs forms, if forms are required.

Thanks for your support!

AK, JC, WW at **Rock Grotto** 2010.

The Complete Board

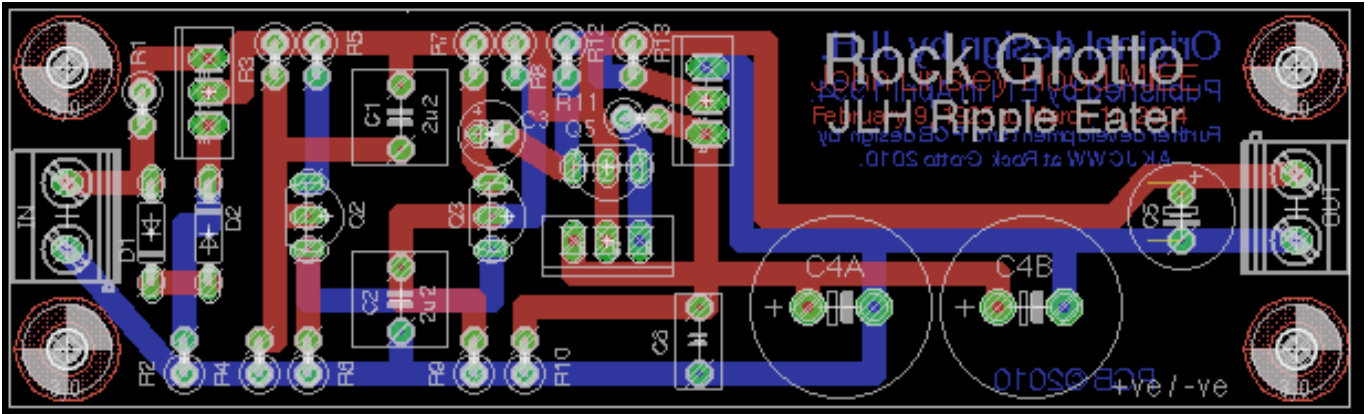

Top Layer

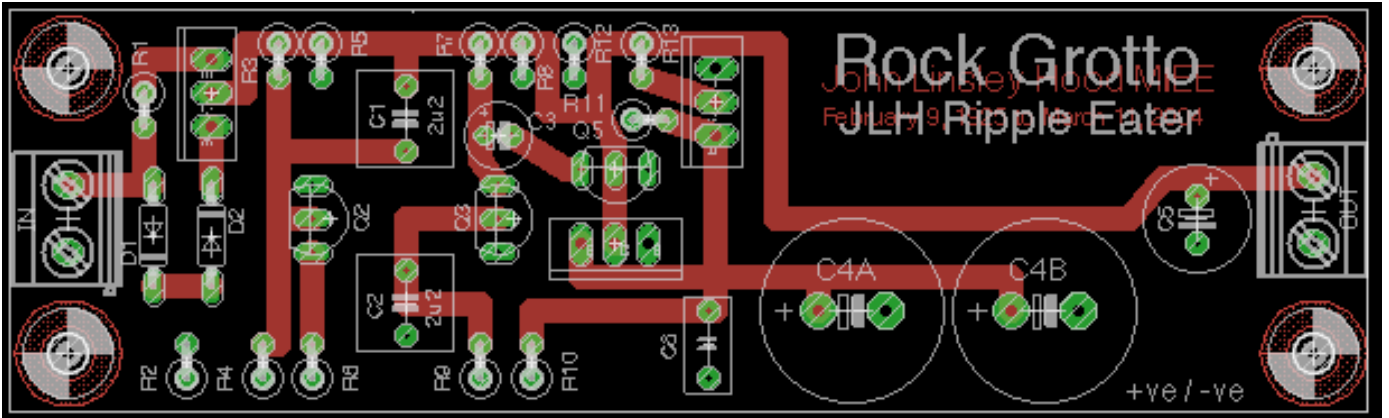

Bottom Layer

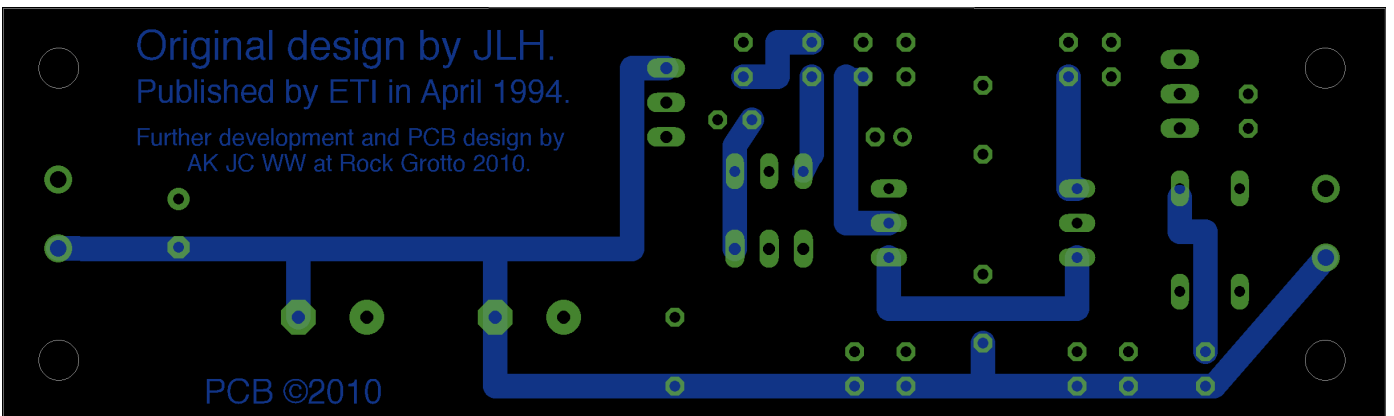

Silk Screen

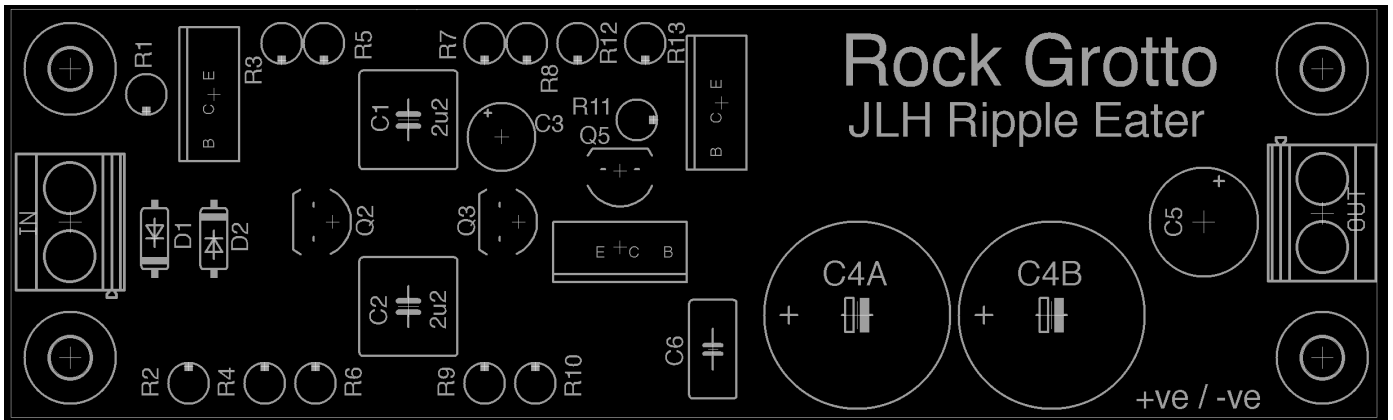

AK Modifications to original circuit

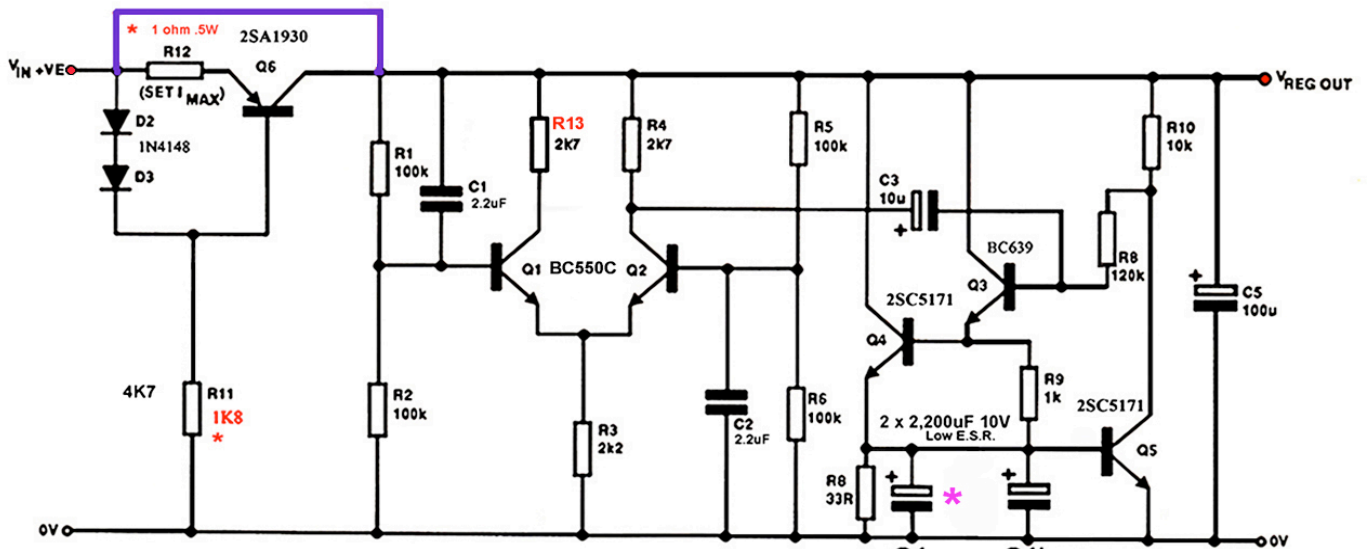

J.L.H. P.S.U. Add on. (8-1-2009)
(Higher current limit version.)

For -VE Rail Version :

1. Reverse the polarity of the diodes and Electrolytic capacitors.
2. Replace 2SA1930 with 2SC5171
3. Replace 2SC5171 with 2SA1930
4. Replace BC639 with BC640.
5. Replace BC549c/BC550C with BC 560C. BC550C/BC560C will enable operation to + and - 40V
6. C3 and C5 voltage ratings are selected to suit voltage rails. Use 25V rating for use with + and -15V rails.

Current Limit = .65V/R12

* Jaycar Cat.no. RE6306 are recommended.

To BYPASS Current limiter, remove Q6 and fit link as shown. (ONLY if preceded by LM78xx/LM79xx or LM317T/LM337T)

* Values shown are for 650mA Current Limit. R13 is additional. Fit for added performance only if Q1 and Q2 are matched.

Part II – Bill Of Materials

MRS25 0.6W resistors have been used to good effect - small size, decent power rating.

POSITIVE VERSION

R1 = 1R 0.5W

R2 = 1K8

R3, 4, 8, 9 = 100K

R5, 7 = 2K7

R6 = 2K2

R10 = 33R

R11 = 1K

R12 = 120K

R13 = 10K

C1, 2 = 2U2 Film (Wima MKS)

C3 = 10uF Electrolytic

C4a, 4b = 2200uF 10V Suntan CD286 from Jaycar RE6306 – or:

C4a, 4b = 4700uF 10V Suntan CD286 from Jaycar RE6308 – for higher current, non-CL applications only.

C5 = 100uF 25V Electrolytic – recommended Panasonic FC

C6 = Optional 100nF (0.1uF) Film (Wima) – fit only if you are NOT using low ESR capacitors.

D1, 2 = 1N4148

Q2, 3 = BC550C

Q5 = BC639

Semiconductor A (Q1) (Current Limiter) = 2SA1930

Semiconductors B, C (Q4, 6) = 2SC5171

NOTE: Panasonic FC 2200uF 10V EEUF1A222 Farnell 969-1979 works well out of the packet, but has not been subject to listening tests at this point.

NEGATIVE VERSION

R1 = 1R 0.5W
R2 = 1K8
R3, 4, 8, 9 = 100K
R5, 7 = 2K7
R6 = 2K2
R10 = 33R
R11 = 1K
R12 = 120K
R13 = 10K

C1, 2 = 2U2 Film (Wima MKS)
C3 = 10uF Electrolytic REVERSE THE POLARITY
C4a, 4b = 2200uF 10V Suntan CD286 from Jaycar RE6306 REVERSE THE POLARITY – or:
C4a, 4b = 4700uF 10V Suntan CD286 from Jaycar RE6308 REVERSE THE POLARITY - for
higher current, non-CL applications only.
C5 = 100uF 25V Electrolytic – recommended Panasonic FC REVERSE THE POLARITY
C6 = Optional 100nF (0.1uF) Film (Wima) – fit only if you are NOT using low ESR capacitors.

D1, 2 = 1N4148 REVERSE THE POLARITY

Q2, 3 = BC560C
Q5 = BC640

Semiconductor A (Q1) (Current Limiter) = 2SC5171
Semiconductors B, C (Q4, 6) = 2SA1930

NOTE: Panasonic FC 2200uF 10V EEUF1A222 Farnell 969-1979 works well out of the packet, but has not been subject to listening tests at this point.

NOTES:

Watch out for pin-outs on the small transistors. Some manufacturers like to swap these about randomly! If in doubt, check your datasheet and the schematic / board image. You may also use the hFE mode on your DMM if it has that facility. This will correctly determine the Emitter, Collector and Base of your device.

As you can see, the NEGATIVE version of populating this board swaps the 2SA1930 and 2SC5171 semiconductors around (i.e. replaces a PNP device for NPN and vice versa), but they go in the PCB the SAME way shown on the silkscreen.

The NEGATIVE version also replaces the Q1, Q2 BC550C with BC560C devices, and the Q3 BC639 with a BC640. Also fitted the SAME way as the silkscreen. Watch your pinouts, though!

HOWEVER, the electrolytic capacitors, C3, C4, C5, and C6 must be fitted REVERSED on the NEGATIVE version. Film caps don't mind which way they are installed, but an electrolytic cap is polarised (directional) and if fitted the wrong way, will go off with a big pop! **Additionally**, the diodes, D1 and D2 must be fitted REVERSED to the silkscreen. Did I say you need to **REVERSE**

the polarity of the electrolytic caps and diodes in the negative version????

Fit -ve power in to left input connector and keep GND on the right (as per the POS version). From Alex's diagram (AK Modifications to original circuit – page 8), and in summary:

Current Limit = $0.65V \times R12$

To bypass the Current Limiter, remove the 2SA1930 (POS) or the 2SC5171 (NEG) limiter, D1 and D2, R1 and R2 and link from +ve or -ve in directly to R3.

Only do this if the PSRR is PRECEDED by an LM78xx/79xx or LM317/337 with built in current limiting, or your PSRR will draw a load of current on start up and go pop!

The Current Limiter (CL) version sometimes hunts around the required voltage while the C4a and C4b capacitors are forming. This is a very low frequency, gentle cycle. It's something we are looking at, because it doesn't always manifest itself with every load. If you are using a preceding limiter (78XX/317 etc), then don't fit the current limiting components at all – just the link as described in the paragraph above. This hunting is apparent when using Suntan 4700uF capacitors, and was evident with the 2200uF parts – both with the larger "Suntan" motif on the body. Therefore, the recommendation is to use 2200uF C4a/b, and only use 4700uF for higher current, non CL versions. However, feel free to experiment between the two. You might like the 4700uF better in your particular application! Panasonic FC 2200uF 10V EEUFC1A222 Farnell 969-1979 showed no hunting (likewise the small motif Suntan caps) out of the packet, but has not been subject to listening tests at this point.

BC550C and 560C will enable operation up to +- 40V. But check CAP RATINGS!!!

C3 and C5 voltage ratings are selected to suit voltage rails. So for 15V rails, use 25V caps, for 40V rails use 63V caps. Might get away with 50V, but I haven't tried this yet. A 55V version is out there, but as I mention, I haven't tried this yet. I intend to, for use on my Pearl phono raw power supplies.

JC

Part III - Building

Introduction

Always, always SAFETY FIRST!! If you're not sure about anything, get help. The best method is to post your question on the build thread over at the Rock Grotto forums.

The BOM and schematic have been checked and double-checked. Sometimes, typos and other errors to creep in to any project. Be organized, sort and check your parts before installation. As factory /supplier mistakes do happen!). Measure resistors. A resistor decode is available for reference at http://en.wikipedia.org/wiki/Electronic_color_code and a capacitor decode here: http://en.wikipedia.org/wiki/Ceramic_capacitor

Building Preparation

Tools required – trousers, good lighting, eye protection, fine-tip soldering iron, solder (Cardas Quad Eutectic recommended), damp sponge, side snips/cutters, de-solder braid, solder-sucker, needle-nose pliers, digital multimeter.

Tools recommended - soldering iron tip cleaner/tinner, pcb holder, insulation tape, magnifying glass, flux pen, fine sandpaper, lead-forming tool, surgical forceps, heat-shunt, heat shrink, oscilloscope, solder/de-solder station.

BOM

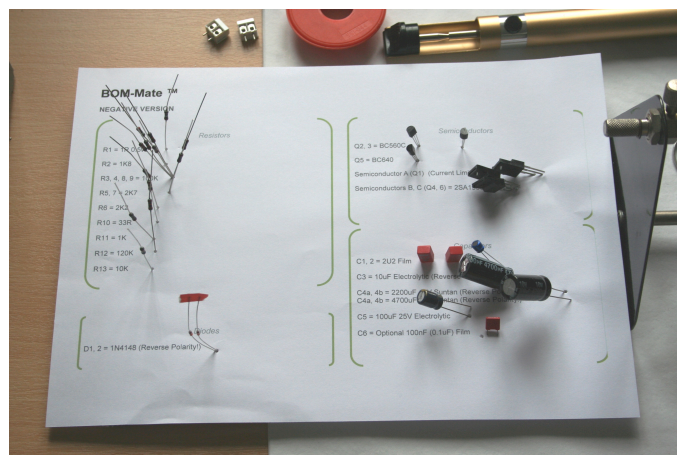

Use the BOM to prepare your components ready for the build. Check and mark each group of components. The BOM Mate™ is a tongue-in-cheek item, but it does save time as the components are measured just the once and then placed into the paper sheets. Use polystyrene sheet or triwall cardboard underneath. It makes populating multiple boards a snap!! You find a pair of BOM Mates™ to download at www.gt6.co.uk.

Building Techniques

Inspect the PCB to ensure all pads are bright and free of corrosion or tarnish. Mount the PCB into a holder, taking care to orientate such to allow easy access to the section of the board you will be

working on,

Take a component and double-check the type and value. Use fine sandpaper to remove any surface corrosion from the leads in order to leave a bright surface.

Form the leads using your fingers, needle-nosed pliers or a lead-forming tool. Form the leads to drop comfortably into the holes on the PCB. You may either bend the leads outwards in order to hold the component in position while soldering, or use a small piece of electrical insulating tape on the component side. This latter method allows for easier de-soldering, as the leads are passing straight through the holes.

Wipe the soldering iron tip on your damp sponge to clean the tip and to ensure it is bright. If it is not, re-tin the tip with solder and repeat. Heat the joint, and while the iron is in place, introduce the solder. Remove the solder and then the soldering iron. You should be left with a small, bright, cone of solder around the lead and pad. Snip the lead flush with the top of the solder joint and, viola, you have a perfect joint. Remove the insulation tape, if you used it, from the silkscreen side of the board. If solder has not flowed through to both sides of the plated holes, apply a little heat with your soldering iron to the component lead at the pad on the component side of the PCB. This will draw the solder through the hole from the bottom side. If needs be, you can use the tiniest dab of solder on the top joint to tidy things up.

This whole soldering process should take less than 5 seconds to avoid overheating the component or PCB pad. Too much heat will destroy a component and will lift a pad/track from the PCB surface. If your joint is dull, it is a “dry” joint and will need to be remade. Let the area cool and then heat again, using your de-solder braid or solder sucker to remove excess solder. Then remake the joint. The heat issue is why low melting point, LEADED, solder is recommended. RoHS compliant, lead-free solder is difficult to work with. Eutectic solder is by far the best as it solidifies at a single, sharp temperature, rather than a non-eutectic solder which has a plastic melting range. Cardas Quad Eutectic solder (Lead, Tin, Copper, Silver) was used in building the demo boards pictured in this manual. It is readily available for reasonable outlay via eBay.

<http://en.wikipedia.org/wiki/Eutectic>

If you have made a mistake and placed a component incorrectly, then you will need to desolder the component completely and remove it from the PCB. Desoldering through-hole-plated boards can be a challenge. One technique for this is to add more solder to the joint. Let it cool a bit then, with sucker ready, heat the joint. Hold that heat for a couple of seconds longer after you see the top joint melt. This ensures that both sides of the joint are molten. Be ready with the sucker and, in one movement, remove the iron and place the sucker. Trigger the sucker immediately and in most cases you'll get the majority of the solder out. If all else fails, get the snips out and cut the component leads. You will have to replace the component, but at least you will be able to de-solder the hole ready for a replacement with a much lower risk of lifting a track.

If you have a lead still in the hole, and enough to grip with tweezers or surgical forceps (which, usefully, are locking), heat the joint and tweezer out the remaining leg. You can use the iron to push from the reverse side of the board in order to get a little more lead to play with. Once you have tweezered out the leg, let the board cool a little. Then add more solder to the via. Let it cool a little and reheat as above, with the sucker ready. Using this method, you'll hopefully end up with a clean through-plated-hole. If you are CAREFUL with the heat, you will not lift a track.

The Build

In general, you would start with the less tall components and work up in height. This is purely to make access with your soldering iron easier. Component orientation is IMPORTANT! As a general rule, anything other than resistors, film capacitors, non-polar capacitors and a standard fuse needs to be correctly orientated on the board. If you get this wrong, your circuit will not work and it is likely you will damage components. In some cases, you will cause a component to overheat or explode, with the obvious consequences. Have a look on YouTube for examples of exploding capacitors! Always wear eye protection when powering up a circuit for the first time.

In this case, however, we will start with the central components and work out way outwards. If you are left handed, you will probably find value in the following order. If you're not gifted, then you'll need to make it up as you go along!! §;0) Start off by installing the small transistors Q2 and Q3. Ensure the pinout on the transistor version you are using is Base, Collector, Emitter when viewed from the front, and that the transistor is installed with the flat face in the same orientation as the silkscreen. The Negative Version of the Ripple Eater uses different parts (see BOM) but with the SAME orientation as the silkscreen. Double-check the values before soldering them in. The orientation of these is not important. Then install Q5. Note that the pinout on this part is Emitter, Collector, Base as viewed from the front.

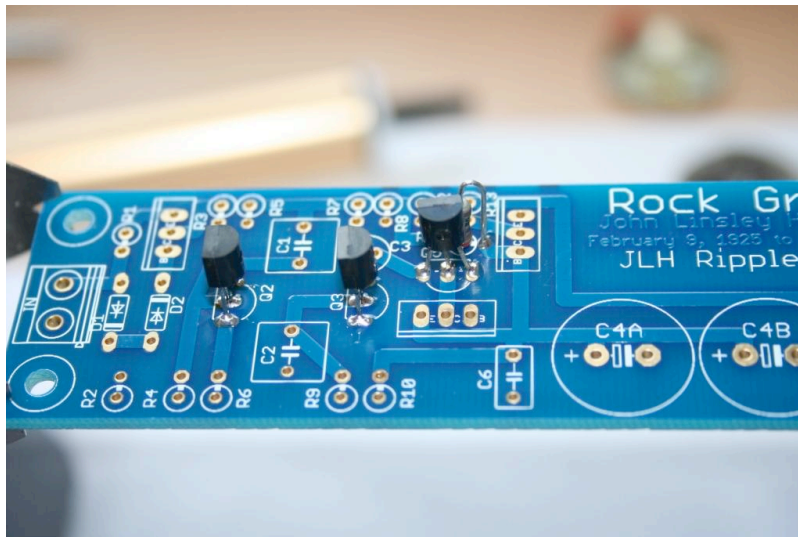

The next stage is to install the resistors. These are mounted vertically to increase density on FR4 real estate. Just bend one lead around a small pair of pliers and parallel to the resistor body. This way, you'll get a neat and consistent lead formed.

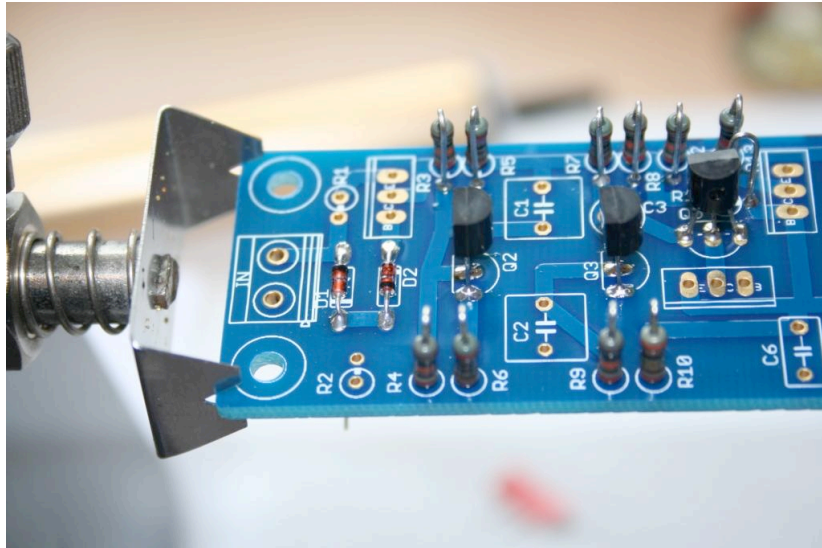

Then install the diodes – pay close attention to the orientation indicated on the silkscreen. The stripe on the diode matches the line on the silkscreen. NOTE: the orientation of these is REVERSED on the NEGATIVE POLARITY version of the Ripple Eater.

If you do not need to fit the Current Limiter, then omit the 2SA1930 (POS) or the 2SC5171 (NEG) limiter, D1 and D2, R1 and R2 and link from +ve or -ve in directly to R3. I've installed the Current Limiter in this build for clarity. You don't need it if you have a limiting device in the PSU feeding the Ripple Eater.

Next fit the Current Limiting transistor Q1, the rest of the resistors and then the caps C1, 2 and 3. Check the orientation of C3!!

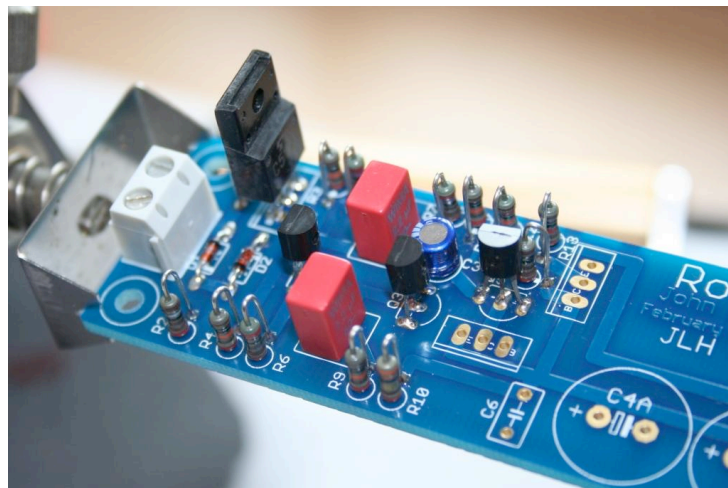

Install the film capacitors. The orientation of these is not important.

Install the large transistors. Make sure the orientation of these Toshiba devices is correct – the line on the silkscreen corresponds to the metal tab on the transistor.

Install the electrolytic capacitors. The stripe on the capacitor body (and the shorter leg) is the negative lead. The positive lead is clearly marked on the silkscreen. NOTE: the orientation of these is REVERSED on the NEGATIVE POLARITY version of the Ripple Eater. Do not get this

wrong – these capacitors will FAIL with a strong possibility of the top safely vent rupturing!!! Also important is the VOLTAGE RATING of C3 and C5. These capacitors see the rail voltage and must be specified accordingly. If you use the Ripple Eater on a 15V supply, then specify 25V capacitors. Always over specify!

Finally, install the connectors. If standard terminals are used, they will only install one way (otherwise your wires won't fit!!!), but if you use a keyed (one way only) Molex connector, be careful to ensure that the power supply is connected in phase and that you haven't swapped the orientation of the base, having already wired up the connector. The "HOT" positive or negative feed goes to the "Northerly" connection point, and GROUND goes to the "southerly" connection point. This applies to both ends of the Ripple Eater.

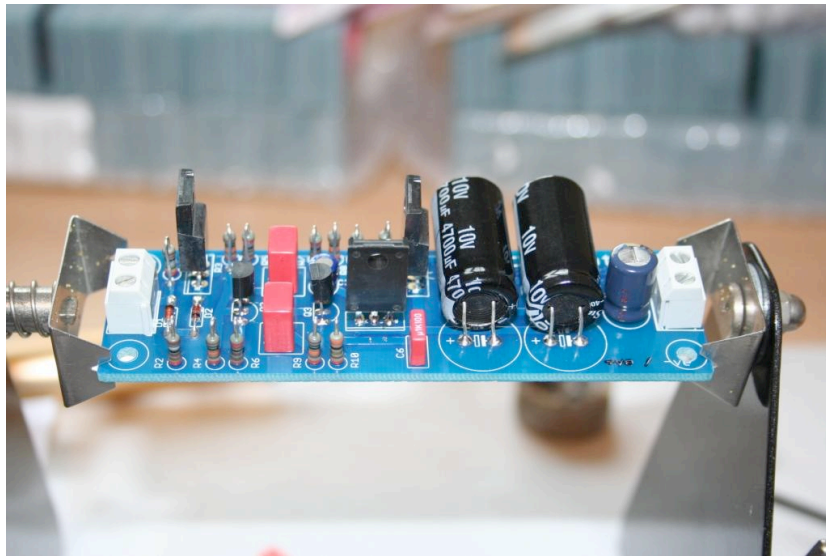

Testing

Make sure you are wearing eye protection.

You should consider a Dim Bulb Tester (Google it up!!) powering up after building or modifying a circuit. The resistance of the bulb filament reduces the amount of current that passes through your equipment. If your gear doesn't work, don't replace the bulb with a higher wattage. Stop, unplug and find the fault. I start off with a 40W bulb, but there is no harm in starting off at a lower wattage. A short circuit or other fault will manifest itself in a couple of ways: Either the equipment will not work and the bulb stays OFF – meaning that little current is being drawn, or the bulb will stay lit, indicating a heavy current draw (possible a short circuit). It is normal for the bulb to flash on switch on as the capacitors in the circuit draw current while they charge.

Hook up the Ripple Eater to your DC power supply. Most builders will be using the Ripple Eater with the Jaycar Headphone Amp kit (KC5417) and the associated PSU board (KC5418). The board in the photos has been modified according to instructions given at Rock Grotto, so might differ from yours. Refer to the Test Points (TP) on the schematic and board image below, and verify that you have similar readings on your digital multimeter. The readings, which are historical ones from the last generation layout, are based on a 15V DC input voltage. These voltage

measurements do not have to be exact; many factors will change their values. However, gross differences should be investigated. Is the input voltage correct? Are all components correctly placed and undamaged? Are all solder joints good (shiny)?

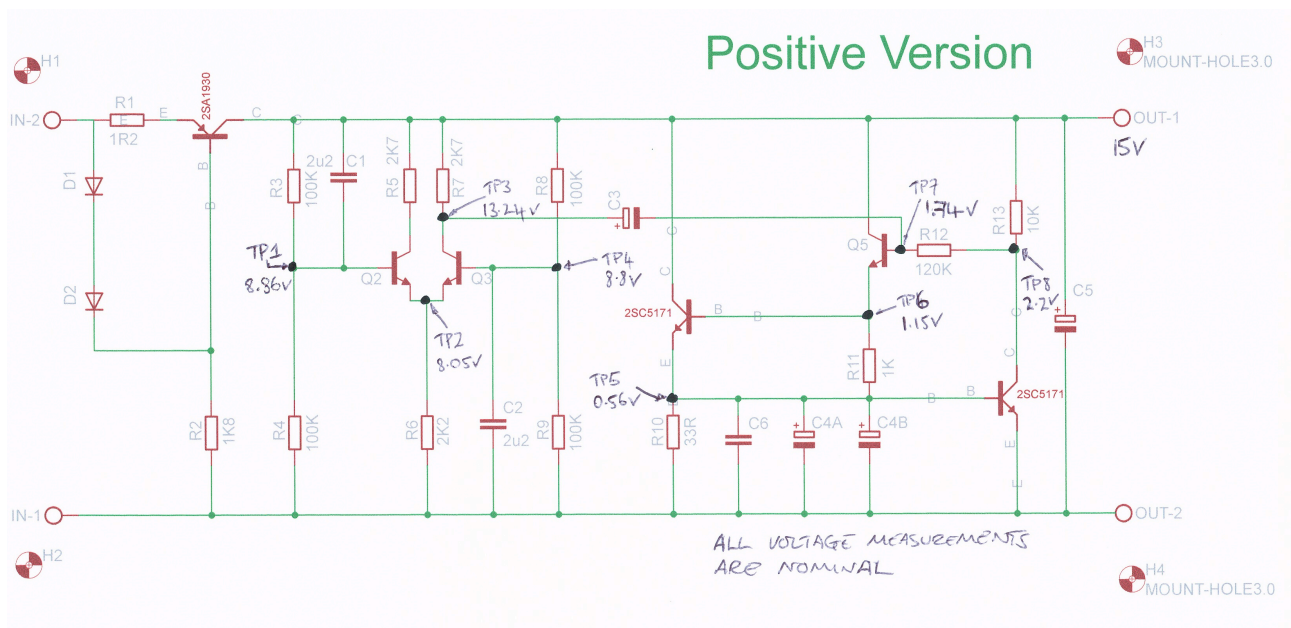
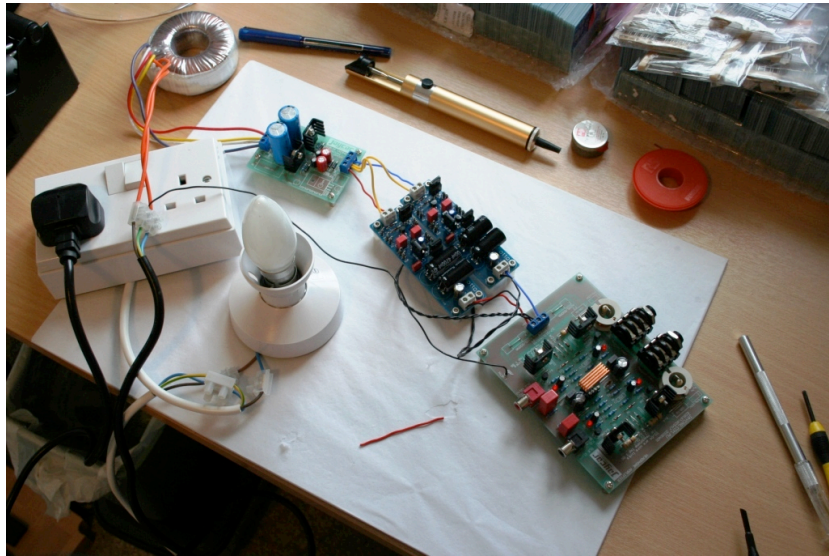

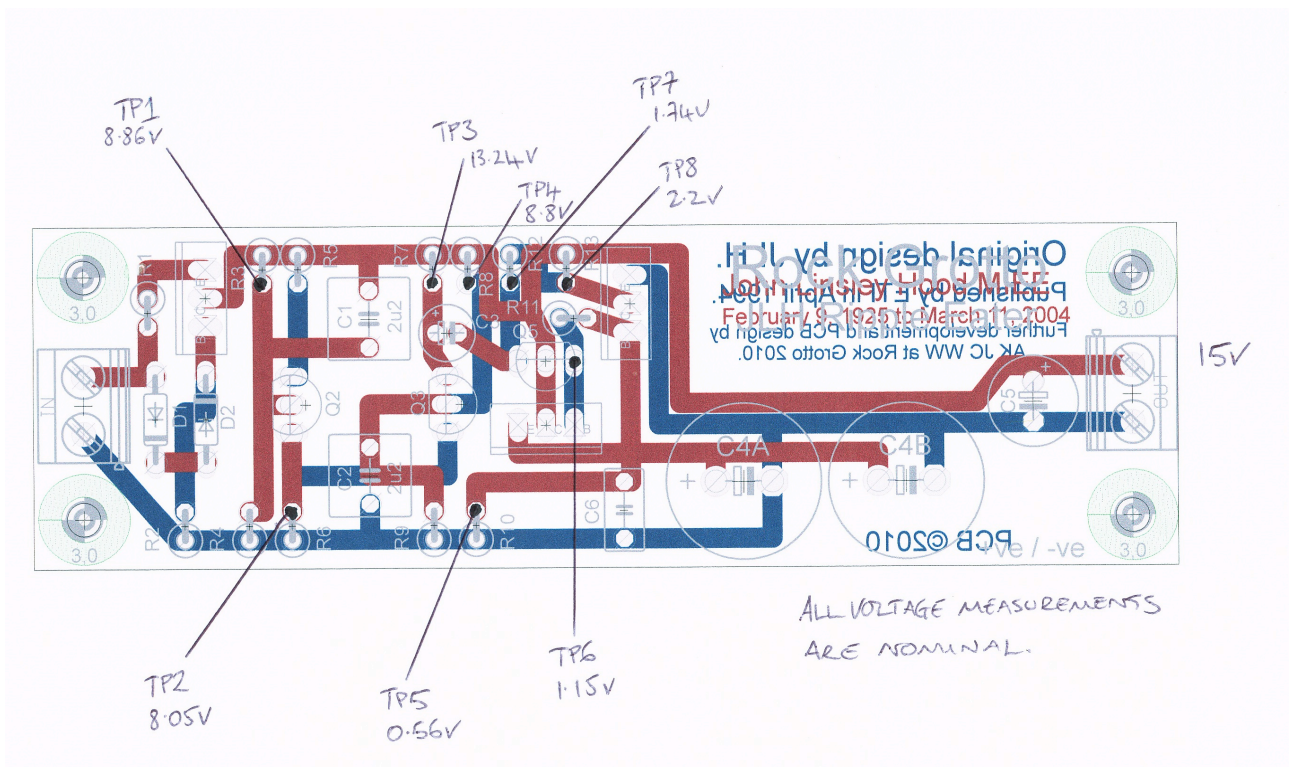

JLH Ripple Eater In Action

Due to time constraints, this small set of experiments has not been conducted. Once they have been completed, this document will be updated and results posted on the Build Thread at the **Rock Grotto** Audio Forum.

A small, unregulated power supply was constructed for this test. Even with a reasonable amount of capacitance on the bridge the ripple is XXX mV. For example, a standard 78XX regulator with 2V dropout, and up to 2.7V higher input voltage required to maintain line regulation, has a typical ripple of around 12mV.

With the Ripple Eater in the circuit the oscilloscope showed that the ripple was reduced from XXXX mV to ZZZZmV.

Part IV – Ordering Information

These boards cost £3 each. Postage is at cost and a charge of £0.15 for packaging will be included in the final postage details. To order, simply select your postage charges from the table below and add this to the board total. Please use PayPal to send this total in GBP to JC-at-CAPT-dot-CO-dot-UK. **If you use the setting for Personal Payment for money owed, there should be no PayPal fees added.** I will refund payments where fees are added, as they are crippling!! Please make sure you include your forum nickname, real name and your preferred mailing address in the Message box if it is different from your normal PayPal delivery address. As soon as I receive your payment, I will prepare your package, cut out and use the address on the payment receipt (that's why I'd like it there and not in another email please!!), and return the other portion as your receipt, plus a copy of the schematic and a board diagram, both showing the test points. Your package will be posted at the earliest opportunity. Once all obligations have been met, donations calculated and made, final accounts will be posted.

All postage is First Class in the UK, and Airmail Small Packet for Europe and ROW. There is not real benefit for the extra expense of "International Signed For" as tracking is only available for the UK portion of the service, and the compensation cover of £41 is the same as the normal Airmail service. Delivery will take around 3 days for European orders and around 5 days for ROW.

Board Number	2	4	6	8	10	12
UK	£0.81	£0.81	£1.11	£1.11	£1.11	£1.11
EUROPE (Including Russia and Turkey)	£1.46	£1.46	£1.57	£1.72	£1.85	£2.13
Rest of World	£1.97	£1.97	£2.25	£2.53	£2.80	£3.55

For orders larger than 12 boards, please email **JC-at-CAPT-dot-CO-dot-UK** for a quote.